

Zero-crossing pulses

The diagram shows a circuit which generates zero-crossing pulses for an optotriac. You are going to assemble it and investigate how it works.

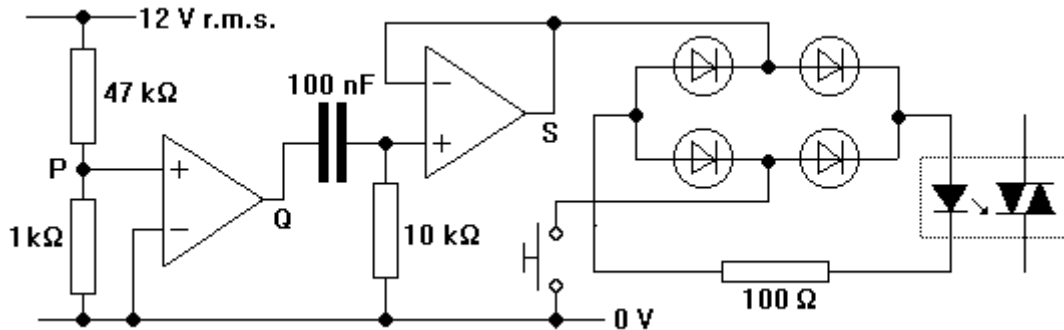

- 1 Connect one terminal of the 12 V a.c. supply to 0 V.
- 2 Assemble the voltage divider and the op-amp comparator (run off the usual supply rails of +5 V, 0 V and -5 V).
- 3 Use an oscilloscope to look at the signal at Q. It should be a square wave with a period of 20 ms.
- 4 Now assemble the spike generator and the op-amp follower. Look at S with an oscilloscope. Can you explain what you see?
- 5 Connect the op-amp follower to the optotriac LED via a diode bridge (using signal diodes), a switch and a 100 Ω current-limiting resistor. Use the optotriac to operate a 12 V lamp, as shown below.

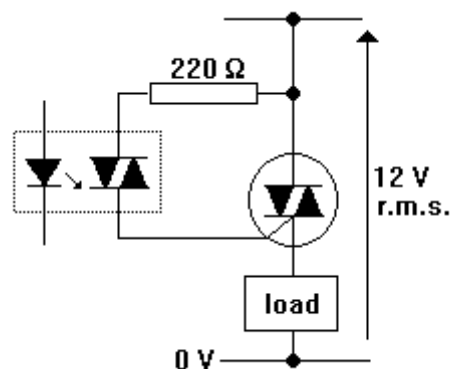

- 6 Check that the lamp lights up only when the switch is closed.
- 7 Use an oscilloscope to look at the voltage across the lamp. Is the lamp only switched on for whole half-cycles of the 12 V a.c. supply?