

One-way intercom

You are going to send voice messages via a modulated current in a pair of wires. The modulator circuit is shown below.

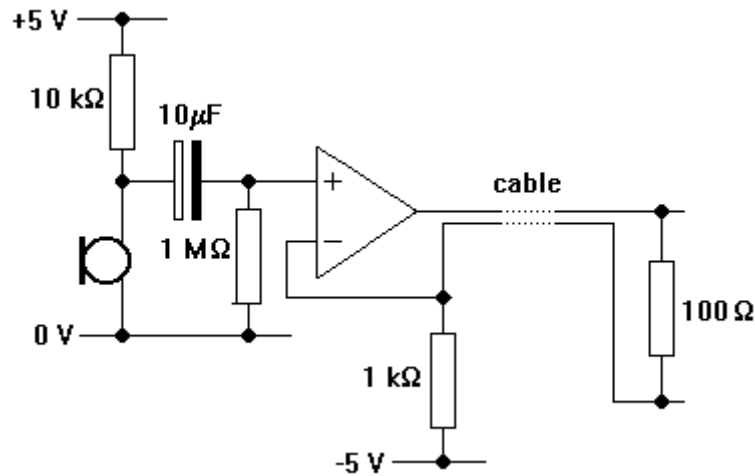

- 1 Assemble the circuit. Don't bother with the cable for the moment. Simply connect the 100 Ω resistor in its place.
- 2 Use an oscilloscope to look at the output of the op-amp. If all is well, there should be a steady +500 mV when there is no sound. Speaking into the microphone should add a small a.c. component to this signal.
- 3 Assemble the demodulator circuit shown below on a separate breadboard. Use an earphone as the speaker.

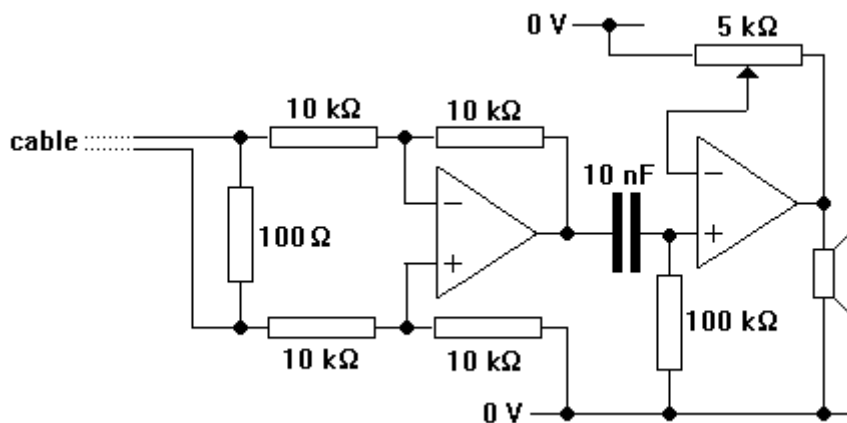

- 4 Connect the modulator and demodulator with a pair of wires twisted together to make a long cable. The longer the better. If all is well, the output of the difference amplifier should be a steady +500 mV, with the a.c. signal from the microphone superimposed on it. The potentiometer adjusts the voltage gain of the amplifier which drives the speaker.
- 5 Use an oscilloscope to look at the signals arriving at the demodulator along the cable. You should find that both wires have picked up a lot of noise on their way from the modulator. Most of that noise should be eliminated by the demodulator.

Investigating tuned circuits

The circuit shown below has a variable frequency oscillator and a bandpass filter.

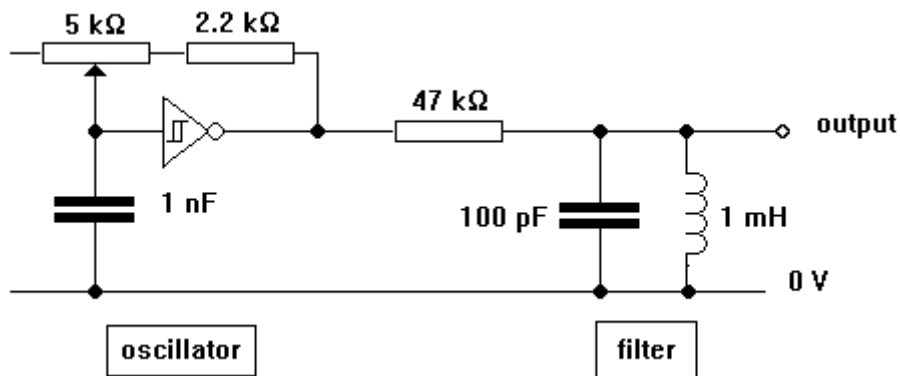

- 1 Assemble the oscillator. Use an oscilloscope to check that its output is a square wave whose frequency can be varied between 250 kHz and 1 MHz. If necessary, alter the values of the fixed resistor and capacitor by trial and error until you can cover this range.
- 2 Add the bandpass filter.
- 3 Look at the output of the filter with the second channel of the oscilloscope. It should be a sine wave - the higher frequency components of the square wave shouldn't get through the filter.
- 4 Note what happens to the amplitude and phase of the output as you sweep the frequency of the oscillator from 250 kHz to 1 MHz. If all is well, the output should peak at about 500 kHz.
- 5 Use the rule $f_0 = \frac{1}{2\pi\sqrt{LC}}$ to calculate the resonant frequency f_0 of the filter.
- 6 Note the effect on the halfwidth of the filter of inserting a 1 kΩ resistor in series with the 1 mH inductor.

Chopping with FSPECTRA

FSPECTRA.XLS is a spreadsheet. It allows you to work out the voltage-time graph (waveform) of a signal if you know the components of its frequency spectrum. You are going to use it to find out how a signal can be modulated and demodulated by chopping.

- 1 Open up the spreadsheet. Set all of the amplitudes (a1 to a10) and frequencies (f1 to f10) to 0.0.
- 2 Set amplitude a1 to 1.0 and frequency f1 to 1.0. Press F9. Take a look at the graphs showing the waveform and its spectrum. Do they make sense?
- 3 Try doubling the amplitude and the frequency in turn. Look at the waveform and spectrum each time.
- 4 The spreadsheet uses the amplitude A and frequency f values you enter to calculate ten different sine waveforms over 2.5 ms, at intervals of 5 μ s. Each waveform is generated by the equation $V = A\cos(2\pi ft)$. The ten waveforms are then added together to give the final waveform which is plotted.
- 5 The circuit below modulates a 2 kHz signal by chopping it on and off at 40 kHz.

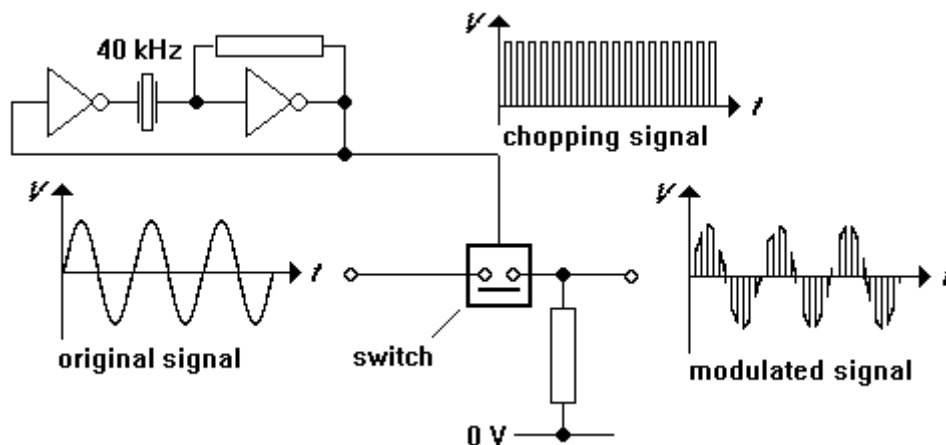

- 6 Set up the spreadsheet so that it generates the waveform of a 2 kHz signal with an amplitude of 2.0 V.
- 7 Add spikes to the frequency spectrum at 38 kHz and 42 kHz, each with amplitudes of 0.56 V. Reduce the amplitude of the 2 kHz signal to 0.88 V. The resulting waveform should look like the original, but chopped on and off at 40 kHz.
- 8 Now filter out the 2 kHz signal by setting its amplitude to 0.0. Look at the resulting waveform. It consists of only the sidebands created by the chopping process. This can be transmitted to another system in a frequency channel centred on 40 kHz with a bandwidth of at least 4 kHz.

Electronics Explained: Analogue Transmission

- 9 When the transmitted signal is received it can be demodulated by chopping it again at 40 kHz. This creates sidebands at 40 ± 38 kHz and 40 ± 42 kHz, giving the frequency spectrum shown in the table.

amplitude (V)	frequency (kHz)
0.25	42
0.25	38
0.31	2
0.15	78
0.15	82

- 10 Enter the frequency spectrum shown in the table. Verify that the waveform has the expected shape (a 2 kHz signal chopped at 40 kHz).
- 11 Filter out all frequencies above 5 kHz by setting their amplitudes to 0.0. The resulting waveform should be a reduced amplitude copy of the original 2 kHz signal.
- 12 Run through steps 6 to 11 for a 1 kHz signal with an amplitude of 1.0 V chopped at 20 kHz.

The next experiment shows you how a square waveform can be built from a number of sine waveforms, using this pair of simple rules.

$$f_n = \frac{2n-1}{T}, \quad A_n = \frac{4V_0 \times (-1)^{n+1}}{(2n-1)\pi}$$

The amplitude and period of the square wave are V_0 and T . The spike number n is a whole number (1, 2, 3,). A_n and f_n are the amplitude and frequency of the spike in the frequency spectrum.

- 13 Calculate amplitude and frequency values for the $n = 1$ spike of a 1.5 V amplitude square wave with a frequency of 500 Hz. Enter it into the spreadsheet. Study the waveform.
- 14 Add the $n = 2$ spike. It will have a negative amplitude. Is the waveform looking more like a square wave?
- 15 Keep on adding the spikes until their amplitude goes below 0.1 V. You should now have a waveform which is a reasonable approximation to a square wave.
- 16 A square wave of amplitude 1.0 V and frequency 1.0 kHz is sent through a filter which rejects all frequencies above 6 kHz. Use the spreadsheet to work out the appearance of the waveform coming out of the filter.

Stacked filters with FILTER

FILTER.XLS is a spreadsheet. It allows you to work out the gain-frequency curve of a stacked filter like the one shown below.

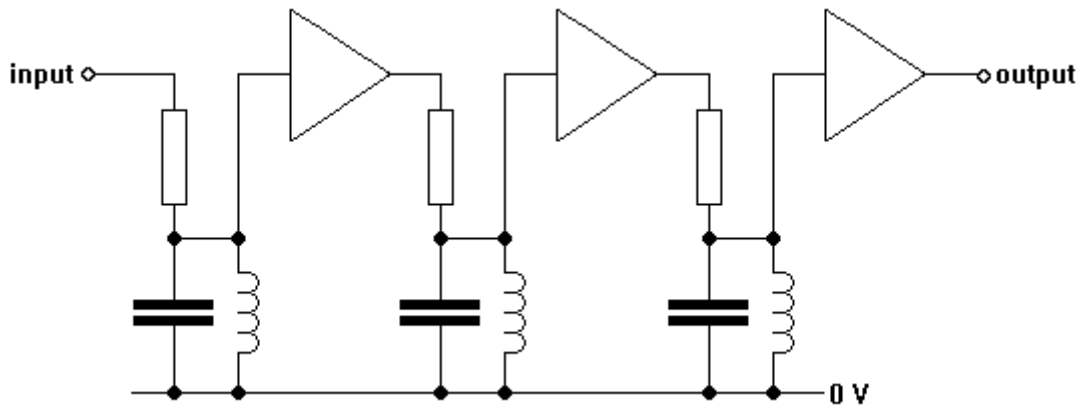

Each of the stages has its own gain, resonant frequency and bandwidth. Your task is to use the spreadsheet to decide values for these parameters which gives a gain-frequency curve like the one below. This is the ideal shape for frequency division multiplexing.

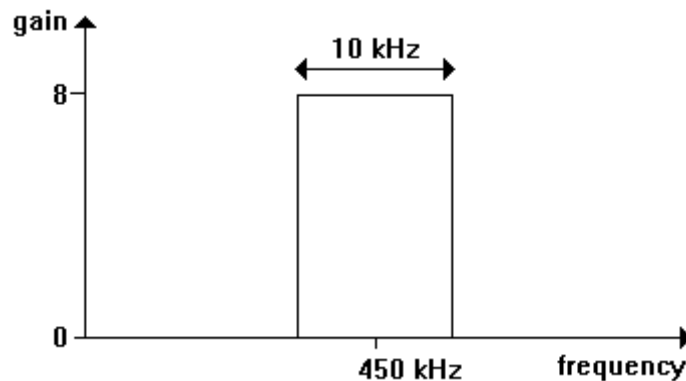

- 1 Open up the spreadsheet. Set the frequency of the first filter to 450 kHz, the bandwidth to 10 kHz and the gain to 8. Turn the other two filters off by giving them frequencies of 500 kHz, bandwidths of 500 kHz and gains of 1.
- 2 Press F9 and view the gain-frequency curve. The black line is the overall gain of the stacked filter circuit. Check that the peak frequency, gain and bandwidth are as expected. Note the effects of changing the frequency, bandwidth and gain
- 3 Give the first two filters the same frequency, bandwidth and gain of 450 kHz, 10 kHz and 2. The overall gain-frequency curve has a bandwidth of less than 10 kHz.
- 4 Give the third filter the same values as the other two. Note the effect on the bandwidth of the overall gain-frequency curve.
- 5 Now set the centre frequencies at 440 kHz, 450 kHz and 460 kHz. Set the gain of each stage to 5. Notice how the gain-frequency curve drops off sharply below 440 kHz and above 460 kHz.
- 6 Use trial-and-error to obtain the ideal gain-frequency curve shown above.

An amplitude modulator

The diagram below shows one way of modulating the amplitude of the signal emerging from an oscillator. It obtains its +5 V supply via a 1 k Ω resistor, so an a.f. signal fed into the capacitor can wobble its supply voltage up and down.

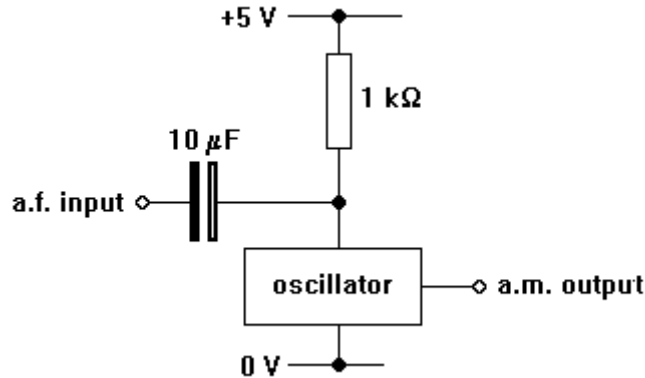

- 1 Assemble the oscillator shown below, making it part of the system shown above.

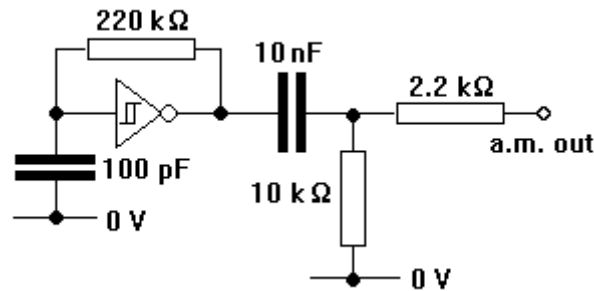

- 2 Look at the output of the oscillator with an oscilloscope. If all is well, it should be a square wave with a frequency of about 100 kHz.
- 3 Use a signal generator to modulate the oscillator with a 330 Hz, 1 V peak value sinusoidal a.f. signal. Note what happens to the a.m. output as the a.f. amplitude and frequency are changed. (Trigger on the a.f. signal.)
- 4 Assemble the demodulator shown below. Use a radio-frequency diode such as a BAT85. You will have to select values for R and C . Verify that the a.f. output has the same shape and frequency as the output of the signal generator.

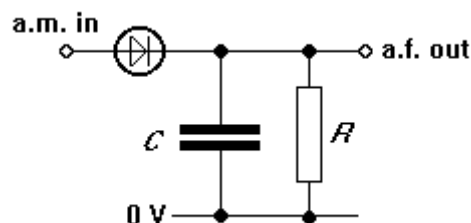

Frequency modulation

- 1 Assemble the frequency modulator circuit shown below.

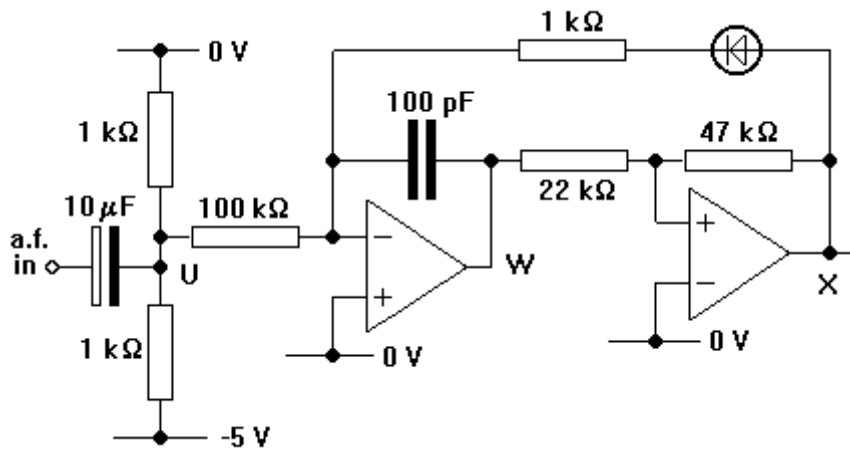

- 2 Use an oscilloscope to look at the signal at X. If all is well, it should spend most of its time at -4 V, pulsing to +4 V at intervals of 16 s.
- 3 Now add the pulse shaper shown below. It generates a square wave output for the modulator. Think carefully about what to do with the R and S inputs of the D flip-flop.

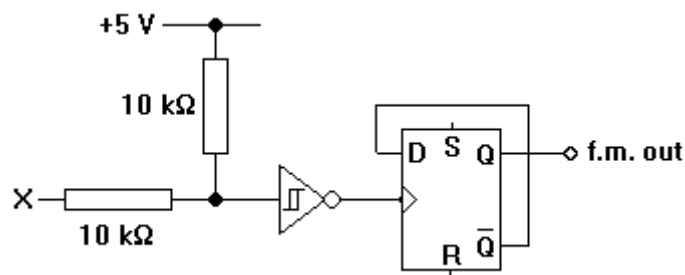

- 4 Use a signal generator to feed an a.f. signal at 330 Hz into the modulator. Trigger the oscilloscope on the a.f. signal. Note what happens to the f.m. output as the amplitude of the a.f. signal is increased.
- 5 Don't take your circuit apart if you are going to tackle the f.m. demodulator practical.

Monostable action

- 1 Assemble the circuit shown below. It employs a relaxation oscillator to trigger a monostable. Start off with $R = 220\text{ k}$ and $C = 10\text{ nF}$.

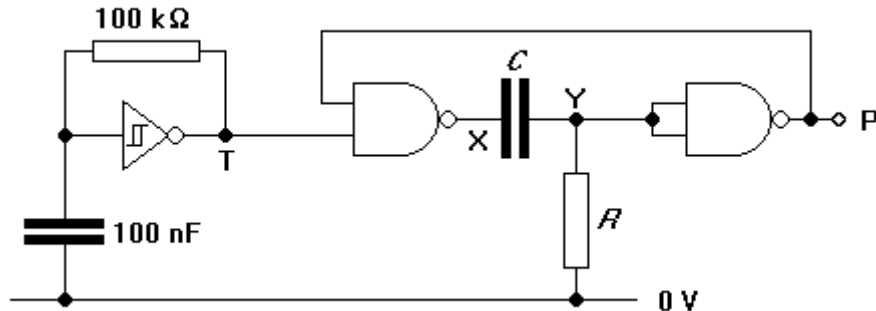

- 2 Look at T with a double beam oscilloscope. If all is well, it should be a square wave with a period of about 5 ms.
- 3 Trigger on the falling edges at T, with the timebase set at 0.5 ms/div. Use the second channel of the oscilloscope to look at P. If all is well, P should pulse low for about 1.5 ms on each falling edge at T.
- 4 Sketch timing diagrams for the signals at T, X, Y and P.
- 5 Measure the duration T of the pulse at P for the values of R and C shown in the table. How well do your results agree with the rule $T = 0.7RC$?

R (k)	C (nF)	T (s)	$0.7RC$ (s)
470	10		
220	10		
100	10		
47	10		
22	10		

- 6 Design a monostable which pulses high for 10 s each time a rising edge triggers it.
- 7 Assemble your design and test it.

An f.m. demodulator

- 1 Assemble the circuit shown below. The variable frequency oscillator feeds pulses into the first part of a demodulator.

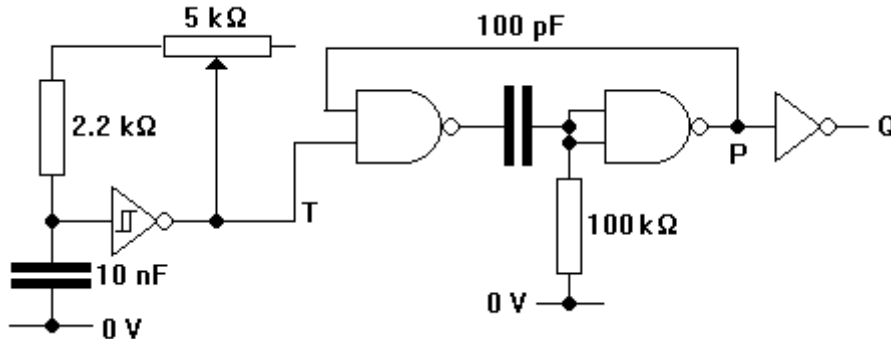

- 2 Use an oscilloscope to verify that the frequency at T can be varied by tweaking the potentiometer. The centre frequency should be about 50 kHz.
- 3 Check that Q is pulsed high for 7 s each time that T goes low.
- 4 The signal at Q needs to be processed by a filter. Design a treble cut filter with a break frequency of 3 kHz and a d.c. gain of 1.0.
- 5 Assemble the filter. Verify that its output has a d.c. component which rises as the frequency at T is increased.
- 6 Obtain data which shows how the voltage at the output of the filter depends on the frequency of the oscillator.
- 7 You might care to remove the oscillator and see how good the system is at demodulating the output of an f.m. modulator.

Modulation bandwidths with FSPECTRA

FSPECTRA.XLS is a spreadsheet. It allows you to work out the voltage-time graph (waveform) of a signal if you know the components of its frequency spectrum. You are going to use it to estimate the bandwidth required for a.m. and f.m. signals.

- 1 Open up the spreadsheet. Set all of the amplitudes (a1 to a10) and frequencies (f1 to f10) to 0.0.
- 2 Set amplitude a1 to 1.5 V and frequency f1 to 20 kHz. Press F9. Take a look at the graphs showing the waveform and its spectrum. Does it look like an unmodulated carrier signal at 20 kHz?
- 3 Now add a pair of sidebands at 21 kHz and 19 kHz, each with an amplitude of 0.5 V. Does the result look like a 20 kHz carrier amplitude modulated by a signal at 1 kHz?
- 4 Note the effect of increasing and decreasing the amplitudes of the sidebands, keeping them the same as each other. How does the depth of the modulation depend on the amplitudes of the sidebands?
- 5 Set up each of the sideband pairs shown in the table below. Keep an amplitude of 0.5 V for the sidebands. Measure the period of the modulation each time.

lower sideband	carrier frequency	upper sideband	modulation period	modulation frequency
19 kHz	20 kHz	21 kHz		
18 kHz	20 kHz	22 kHz		
17 kHz	20 kHz	23 kHz		
16 kHz	20 kHz	24 kHz		

- 6 Calculate the modulation frequencies. How are they related to the bandwidth required to carry the modulated signal?
- 7 The diagram shows how an a.m. signal can be demodulated with a diode.

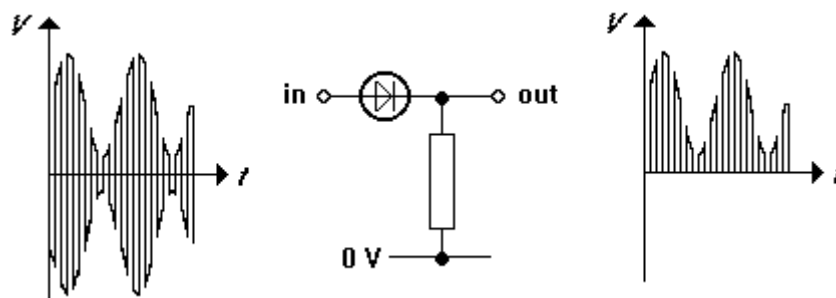

The process of rectification adds the following spikes to the frequency spectrum:
 A spike at 0 Hz, with the same amplitude as the carrier.
 A spike at the modulation frequency with twice the amplitude of the sidebands.

Use FSPECTRA to check this rule for the a.m. signal in step 3.

Electronics Explained: Analogue Transmission

The next set of instructions will give you a feel for the bandwidth required to accommodate frequency modulated carriers.

- 8 Set up a single spike at 7.5 kHz with an amplitude of 2.0 V. This is the unmodulated carrier. Look at its waveform.
- 9 The 7.5 kHz carrier is going to be frequency modulated by a 1 kHz square wave, switching the 7.5 kHz carrier between 5 kHz and 10 kHz. Use FSPECTRA to see what both of these waveforms look like.
- 10 Now set up the frequency spectrum shown in the table. Its waveform should look like a 5 kHz carrier being switched on and off at a rate of 1 kHz.

amplitude (v)	frequency (kHz)
-0.23	2
+0.70	4
+1.10	5
+0.70	6
-0.23	8

- 11 Add the extra components shown in the table below. The result should look like a carrier signal being switched between 5 kHz and 10 kHz at a rate of 1 kHz.

amplitude (v)	frequency (kHz)
+0.23	7
-0.70	9
+1.10	10
-0.70	11
+0.23	13

- 12 You have built up the waveform and spectrum of a frequency modulated signal with the following properties.
 - a carrier frequency of 7.5 kHz
 - a deviation frequency of 2.5 kHz
 - a signal frequency of 1 kHz
- 13 Now build up the waveform and spectrum of an f.m. signal with these properties.
 - a carrier frequency of 15 kHz
 - a deviation frequency of 3 kHz
 - a signal frequency of 2 kHzDoes the waveform look as if it is being switched between 12 kHz and 18 kHz at a rate of 3 kHz? What is the bandwidth required?
- 14 Now restrict the bandwidth to five times the signal frequency. Does this make much difference to the f.m. signal waveform?
- 15 Finally, keeping the bandwidth fixed at 10 kHz, investigate the effect of reducing the signal frequency to 1 kHz and 500 Hz.

Assembling an a.m. radio receiver

The circuit you are going to assemble is shown below. Once you have evaluated its performance, you will be able to add other components to improve its selectivity and sensitivity.

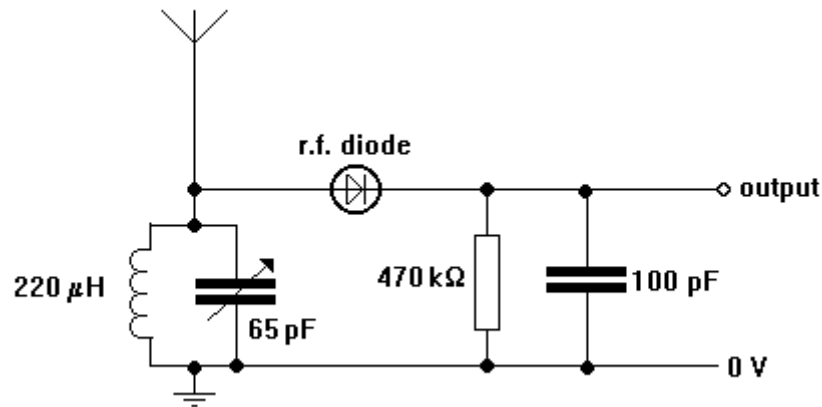

- 1 Assemble the tuned circuit on your breadboard. Leave out the rest of the circuit for the moment. The aerial is a long length of wire. Try attaching one end to the ceiling. It is important that the 0 V supply rail is properly earthed.
- 2 Use an oscilloscope to look at the r.f. signal at the base of the aerial. Set the timebase to 2 ms/div and the vertical sensitivity to 10 mV/div. Tune the variable capacitor until you obtain a recognisable a.m. signal.
- 3 Experiment with the layout of the aerial to obtain the maximum r.f. signal. Try different inductor values (1000 H, 470 H). Find the strongest station.
- 4 Now add the diode detector to your breadboard. Use a low voltage-drop radio-frequency diode such as a BAT85.
- 5 Use the oscilloscope to verify that there is an a.f. signal at the output of the circuit.
- 6 Use a piezoelectric earphone to listen to the a.f. signal at the output. Try tuning into different stations.

Improving the performance of an a.m. radio receiver

Here are some suggestions for improving the performance of the simple radio receiver circuit. Be warned. It is quite easy for high gain radio-frequency amplifiers to turn into oscillators!

- 1 Add the MOSFET follower shown below. The 100 nF capacitors prevent positive feedback through the supply rails.

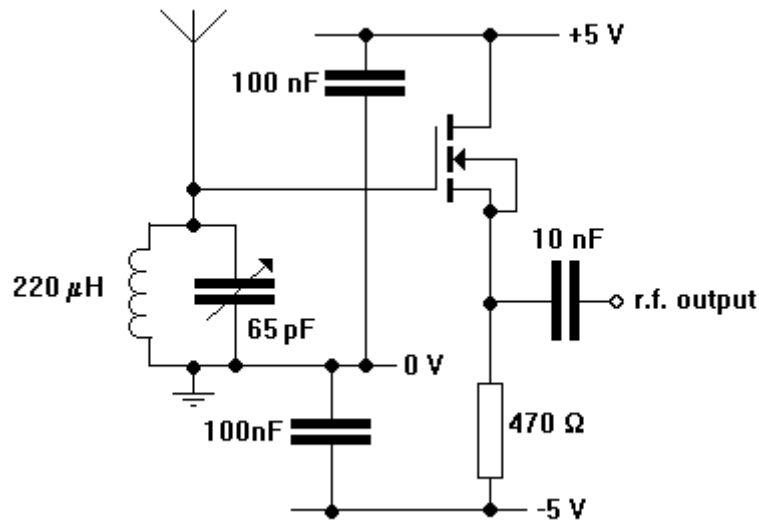

- 2 Use an oscilloscope to look at the r.f. output of the circuit. Tune into the strongest station. If all is well, you should find that the addition of the follower has improved both the selectivity and sensitivity of the receiver.
- 3 Now add an r.f. amplifier to boost the signal before feeding it into the diode detector. The circuit shown below is probably the easiest way of doing this. Run the NOT gate off supply rails at +5 V and -5 V.

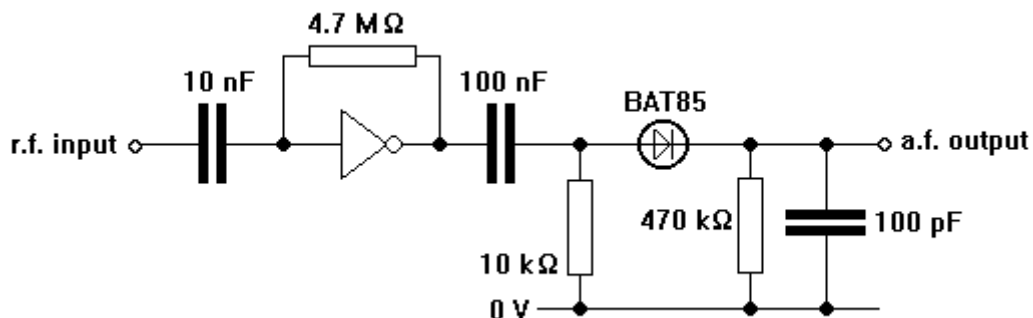

- 4 Check that there is an audio frequency signal at the a.f. output. Look at the r.f. signals entering and leaving the r.f. amplifier. How much gain is it providing?

- 5 Finally, add a variable gain audio amplifier stage with a power amplifier capable of driving a loudspeaker. Make sure that the 0 V lead of the speaker goes directly to the power supply. Large a.f. currents in the 0 V rail of your breadboard are bound to lead to positive feedback with unwanted consequences!

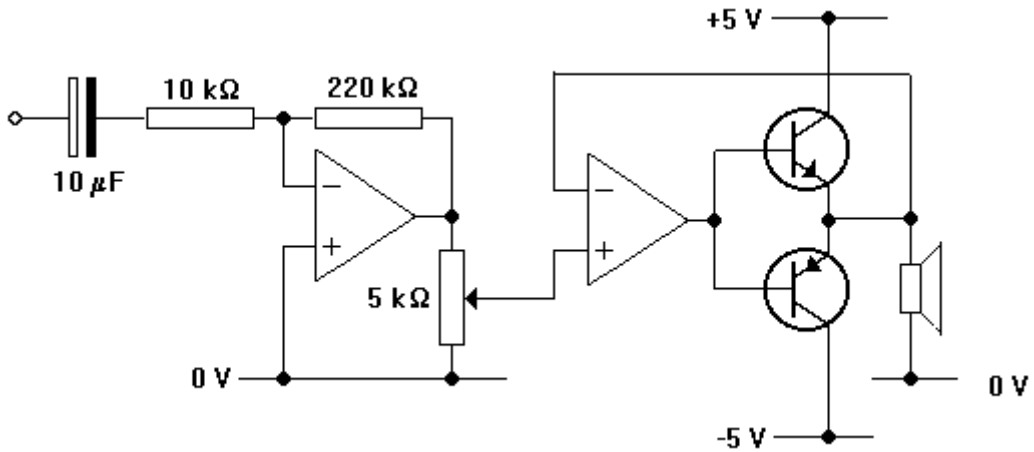

Measuring your flicker threshold

- 1 Assemble the circuit shown below. Start off with R as $4.7\text{ M}\Omega$, so that S has a frequency of about 4 Hz .

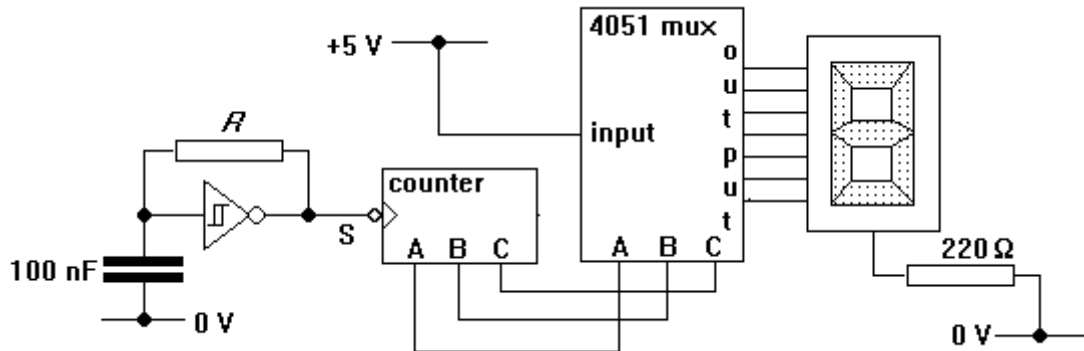

- 2 If all is well, each LED in the seven segment display should light in turn. You should be able to see this clearly.
- 3 Replace R with $2.2\text{ M}\Omega$, $1\text{ M}\Omega$, $470\text{ k}\Omega$, $220\text{ k}\Omega$ until the display shows a flicker-free number eight.
- 4 Use an oscilloscope to measure the number of times that one (any one) of the LEDs is turned on in one second. This is your threshold flicker frequency.

Studying VGA monitor signals

You will need to be able to probe the connections between a computer and its VGA monitor with an oscilloscope. The computer will need loading with software which can paint its screen in various patterns of colours.

- 1 The pins you need access to are shown below, looking into the socket of the computer. You should be able to insert breadboard wire straight into the holes.

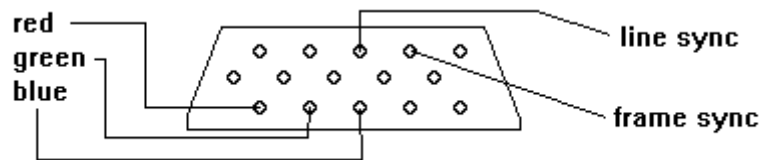

- 2 Look at the line and frame sync signals with the oscilloscope. Sketch their waveforms, with suitable scales. Calculate the frame rate and the number of lines per frame.
- 3 Display one cycle of the line sync signal on the oscilloscope screen.
- 4 Use the other channel of the oscilloscope to display the red signal. Paint the screen with alternating vertical stripes of red and black. Sketch the waveform of the red signal.
- 5 Paint one vertical stripe of each colour shown in the table, so that they fill the width of the screen between them.

colour
black
blue
green
cyan
red
magenta
yellow
white

- 6 Sketch the red, green and blue waveforms as seen on the oscilloscope screen. Explain their shapes.