

Exploring an op-amp

This experiment will help you unravel the behaviour of an operational amplifier (op-amp).

1. Assemble the circuit shown below. Use supply rails at +5 V, 0 V –5 V.

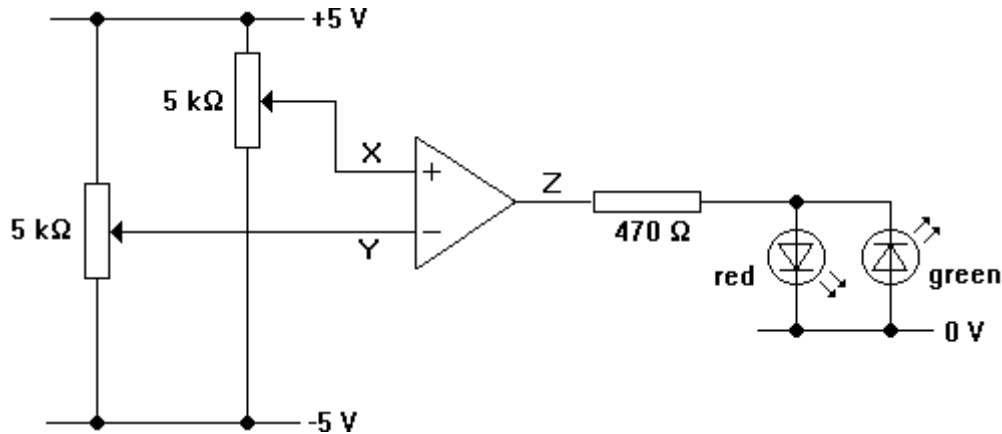

2. Use a voltmeter to measure the voltage at Z, the op-amp output. Vary the settings of the potentiometers until the red LED glows. Note the voltage at Z.
3. Measure the voltage at Z when the green LED glows.
4. Connect the voltmeter to X. Set X to +1.5 V. Connect the voltmeter to Y. Slowly raise Y from -4 V to +4 V. Note the voltage at which the op-amp output changes.
5. Use your observations to plot a graph of the voltage at Z (vertical) against the voltage at Y for X at +1.5 V. Set out the axes as shown below. You should be able to draw it out of three lines (two horizontal and one vertical).

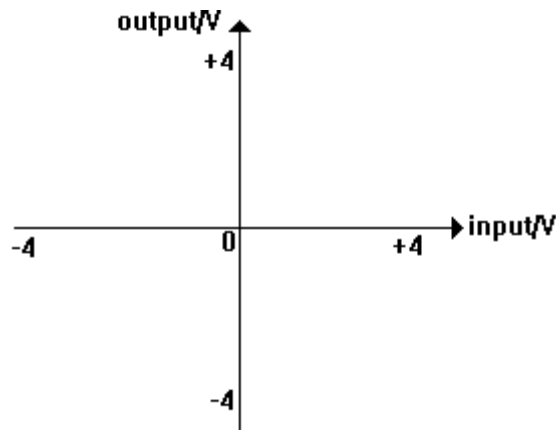

6. Repeat 4 and 5 for X set at 0.0 V and -1.5 V.

Sensing the light

You are going to design and test a simple light sensor circuit.

1. Put together an LDR and 10 kΩ resistor as a voltage divider between 0 V and +5 V. Its output (the light signal) must be high in bright light and low in dim light.
2. Use a 4.7 kΩ resistor and a 2.2 kΩ resistor to generate a reference voltage of about +1.6 V.
3. Use 10 kΩ and 22 kΩ resistors to generate another reference voltage of about +3.4 V.
4. Use an op-amp to compare the light signal with +1.6 V. Arrange it so that an LED (via a 220 Ω resistor) glows when the light signal goes above +1.6 V.
5. Use another op-amp to make another LED glow when the light signal goes above +3.4 V.
6. Add a third op-amp to make a third LED glow when the light signal goes above +2.5 V. You will have to decide on the resistors for the voltage divider.
7. The number of glowing LEDs on your breadboard tells you how much light is falling on the LDR. As the amount of light increases, so does the number of LEDs. Adapt your circuit so that only one LED glows at any one time, according to this table.

light level on the LDR	colour of glowing LED
low	red
medium	yellow
high	green

It may help you to study this circuit. The LED glows when the thermistor is warm, but doesn't glow when it is hot or cold.

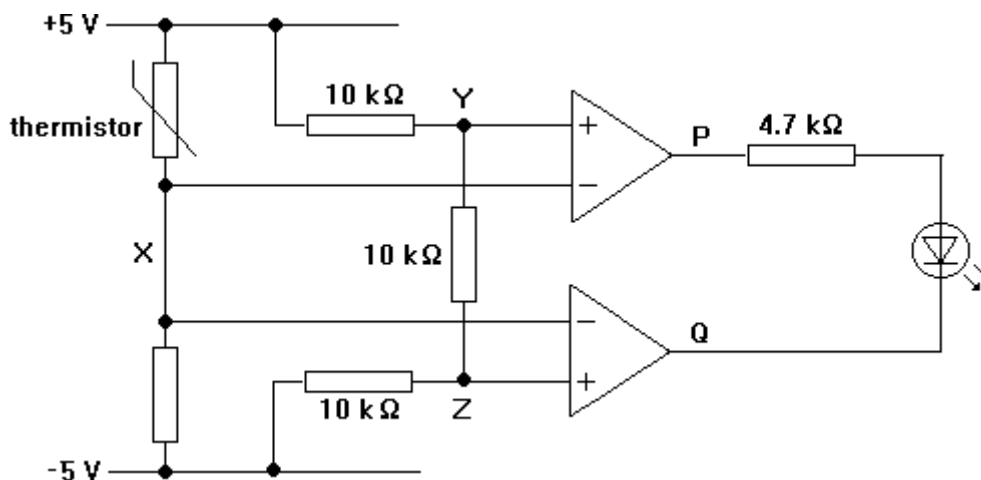

Output impedance of a microphone

1. Set up the circuit shown below with $R = 100\ \Omega$. The microphone is an electret one, so it needs a $10\ \text{k}\Omega$ pull-up resistor. Use a CRO to look at the signal at OUT.

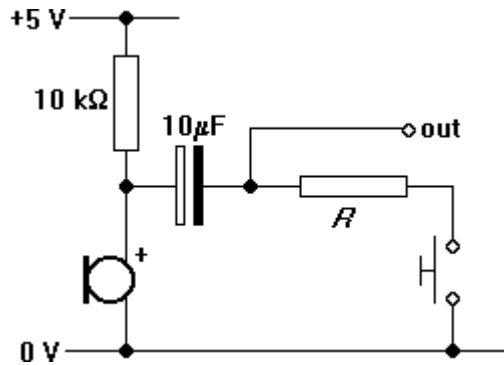

2. Sing a note into the microphone and see what happens to the CRO trace when you press and release the switch.
3. By trial and error, find a value of R which halves the peak value seen on the CRO screen when the switch is pressed.
4. Explain why this value of R is the output impedance of the microphone circuit.

Measuring the gain of an amplifier

1. Construct the a.c. amplifier shown below using a 4069 NOT gate run off supply rails at +5 V and 0 V.

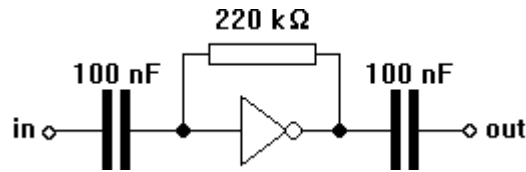

2. Use a signal generator to feed a 20 mV peak value sine wave at 1 kHz into the amplifier. Use a double-beam CRO to compare the signals at the output and the input.
3. Measure the peak values of both traces on the CRO screen. Use them to calculate the voltage gain of the amplifier (it should be between 30 and 50). Is it positive or negative?
4. Repeat the experiment for each of the input amplitudes shown in the table. Keep the frequency at 1 kHz and study the output waveforms for distortion.

Input amplitude/mV	Output amplitude/mV	voltage gain
20		
50		
100		
200		
500		

5. Now investigate how the gain of the amplifier depends on frequency of the input signal. Set the input amplitude to 20 mV. Measure the voltage gain at each of these frequencies in turn:

100 Hz 330 Hz 1 kHz 3.3 kHz 10 kHz 33 kHz.

6. Use your to plot a gain-frequency graph for the amplifier on the axes below.

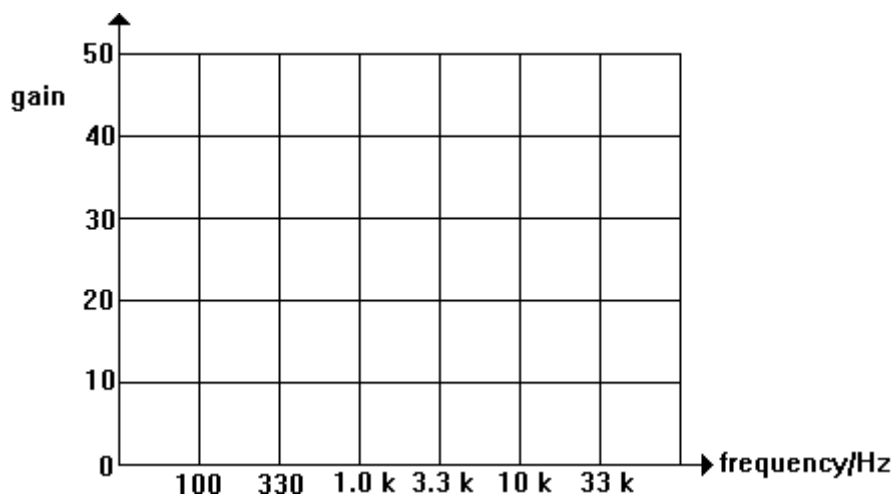

The input impedance of an oscilloscope

1. Connect a signal generator directly to a CRO. Adjust the signal generator so that it feeds out a signal with a peak value of 800 mV and a period of 4 ms. Don't adjust the signal generator for the rest of the experiment.
2. Now place a 100 k Ω resistor between the output of the signal generator and the input of the CRO as shown below.

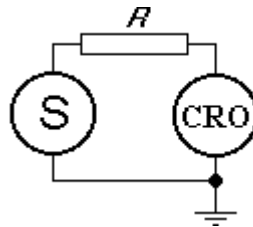

3. Measure the amplitude of the signal detected by the CRO.
4. Repeat step 3 for the other resistors shown in the table.

$R/k\Omega$	amplitude/mV
100	
220	
470	
1000	
2200	
4700	

5. Plot a graph to show how the signal at the CRO input depends on the value of R .
6. Explain why the value of R which gives an amplitude of 400 mV is the input impedance of the CRO.

Non-inverting amplifiers

1. Construct the circuit shown below, with $R = 4.7 \text{ k}\Omega$.

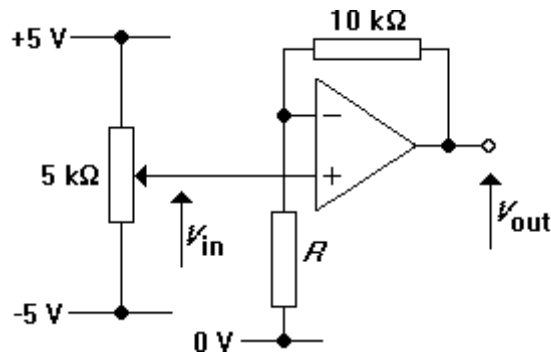

2. Use a double-beam CRO to measure the values of V_{in} and V_{out} . If all is well, V_{out} should rise from about -3 V to $+4 \text{ V}$ as V_{in} is raised from -4 V to $+4 \text{ V}$.
3. Measure the value of V_{out} for values of V_{in} covering the range $+4.0 \text{ V}$ to -4.0 V at intervals of 0.5 V .
4. Plot your results on a $V_{\text{out}}-V_{\text{in}}$ graph. Join the points with three straight lines.

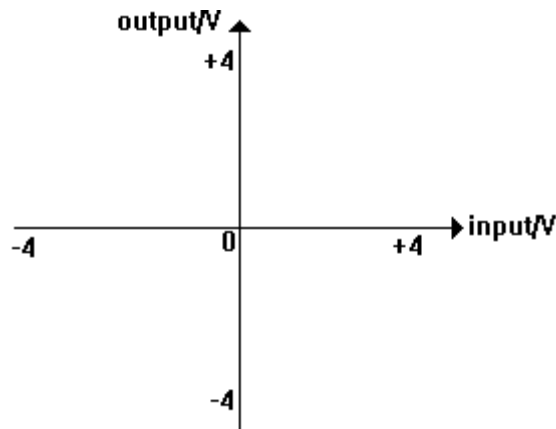

5. Calculate the voltage gain from the graph. Check that its value agrees with the formula $G = 1 + R_f/R_d$.
6. Repeat the experiment for $R = 10 \text{ k}\Omega$ and $1 \text{ M}\Omega$.

Inverting amplifiers

1. Assemble the circuit shown below.

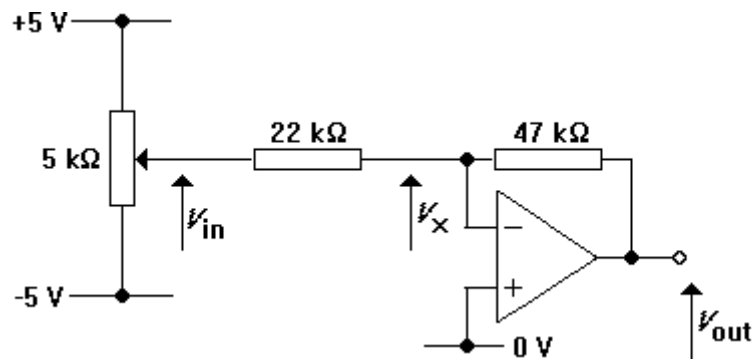

2. Use a double-beam CRO to measure the values of V_{in} and V_{out} . If all is well, V_{out} should drop from +4 V to -3 V as V_{in} rises from -4 V to +4 V.
3. Measure the value of V_{out} for values of V_{in} covering the range from -4.0 V to +4.0 V at intervals of 0.5 V.
4. Plot your results on a V_{out} - V_{in} graph. Join the points with three straight lines.

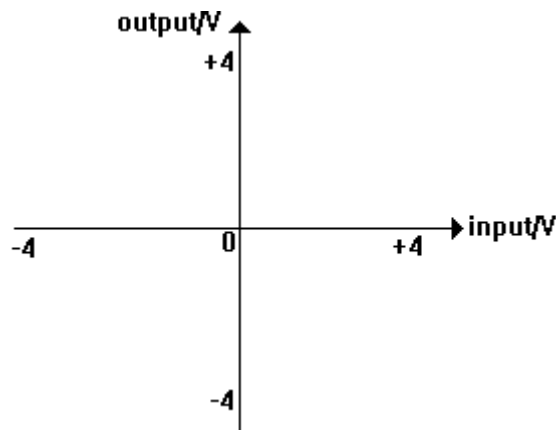

5. Calculate the voltage gain from the graph. Check that its value agrees with the formula $G = -R_f/R_{in}$.

Designing a sound-to-light converter

The circuit diagram of this circuit is shown below. The LED should glow when enough sound enters the microphone. You will design and test circuits for the blocks.

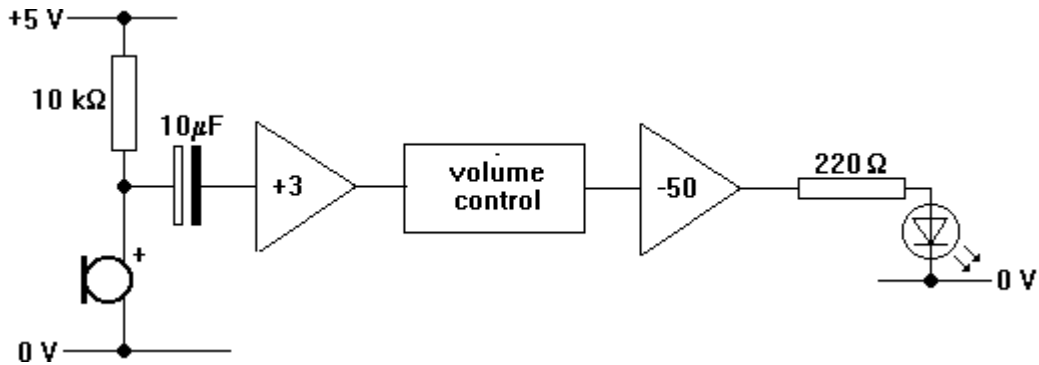

1. Design circuits for the non-inverting amplifier, the volume control and the inverting amplifier.
2. Assemble each circuit separately. Test the behaviour of each one with a signal generator and an oscilloscope.
3. Add the microphone input and the LED output to make the whole circuit. Check that it functions as specified.

Investigating a power amplifier

The diagram below shows the circuit which you will be using to test the behaviour of a push-pull follower.

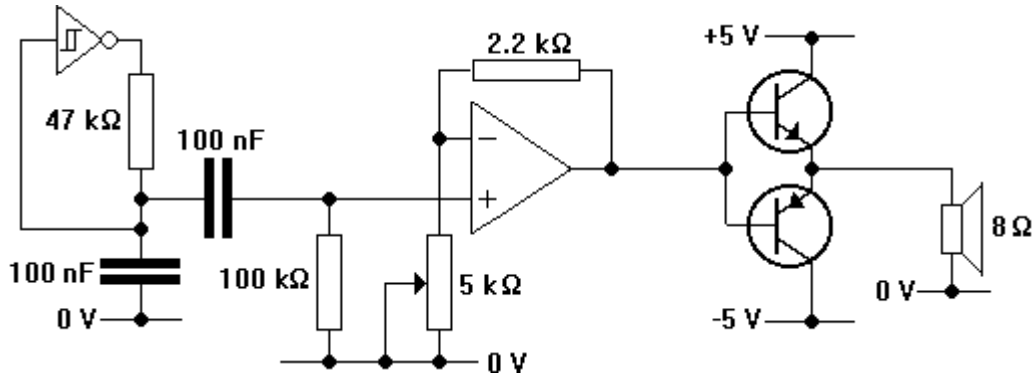

1. Start off by assembling the relaxation oscillator on the left. Run the 40106 Schmitt trigger NOT gate from +5 V and -5 V instead of +5 V and 0 V. If all is well, its output should be a 500 Hz triangle wave with a peak voltage of about 500 mV.
2. Build the non-inverting amplifier. Use a CRO to check that adjusting the potentiometer alters the amplitude of the signal at the amplifier output.

3. Put together the push-pull follower, using power transistors, but don't insert the speaker yet. Use the CRO to check that the a.c. signal at the emitters is distorted.

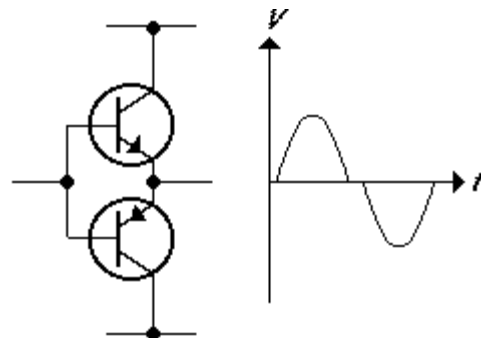

4. Adjust the amplifier to its minimum gain ($\neq 1$). Connect the speaker to the output of the push-pull follower.

5. Use a double-beam CRO to look at the signals at the bases and emitters of the transistors. Slowly turn up the gain of the amplifier. Note what happens to the CRO trace and the sound from the speaker.

6. Now place the push-pull follower inside the feedback loop of the non-inverting amplifier (similar to the arrangement shown opposite). Repeat step 4.

